

CONTRACTILE RESPONSE IN ISOLATED HUMAN GROIN LYMPHATICS

T. Sjöberg, P. Alm, K.-E. Andersson, L. Norgren, S. Steen

Departments of Surgery, Clinical Pathology, and Clinical Pharmacology, Lund University, Lund, Sweden

ABSTRACT

Lymphatics from the human superficial groin removed at operation in 21 patients (one with lymphedema) were examined in vitro. Histochemically no nerves were identified with either specific catecholamine fluorescence or immunoreactivity to tyrosine hydroxylase or dopamine β -hydroxylase. Ring preparations of the lymphatics were mounted in tissue baths and isometric induced contractions were recorded after administration of K^+ (124mM), acetylcholine, selected amines and prostanoids. Noradrenalin (NA), adrenalin, dopamine, and acetylcholine had no or only weak contractile effects. In some segments, serotonin induced contractions. Prostaglandin E_2 showed no contractile effect and prostaglandin $F_{2\alpha}$ induced contraction in most of the tested lymphatics. The prostaglandin-endoperoxide analogue U44069 uniformly elicited marked concentration-dependent contraction. In the lymphatic segment from the patient with lymphedema, a slightly greater contractile response to NA and serotonin was observed. The results overall suggest an absence of sympathetic innervation and contraction-mediating α adrenergic receptors in human superficial groin lymphatics, and support that certain prostanoids may be important regulators of human lymphatic contractility.

The propulsion of lymph has been attributed to several factors including an intermittent compressing effect of skeletal muscles, pulsations in neighboring arteries,

and respiratory movements (1). However, investigations in animals have shown that lymphatics have rhythmic contractions and it is widely accepted that in lymphatics from some regions, smooth muscle tone can be modified by humoral as well as nervous factors (2-4). Thus, bovine mesenteric lymphatic contractions may be induced by serotonin (5-HT), noradrenalin (NA), prostaglandin $F_{2\alpha}$ ($PGF_{2\alpha}$), dopamine, histamine and acetylcholine (5). Histochemical and electron microscopic studies have also indicated the presence of adrenergic fibers in mesenteric lymphatics (6,7), and functional investigation suggests that bovine mesenteric lymphatics have a noradrenergic innervation capable of controlling lymph flow (8). It has also been shown that lymphatics display myogenic control, i.e., distension of the smooth muscle cells trigger contractile activity (9). "Intrinsic" lymphatic contractions have been observed in man (10) but studies on the mechanism(s) regulating this contractility are few. Sinzinger et al (11) showed that thromboxane A_2 (TXA_2) promoted contraction of isolated human peripheral lymph vessels and suggested this agent played an important role in human lymphatic contraction. Whether adrenergic nerves are present in human leg lymphatics is, to our knowledge, not known. It is also unknown what agents may be involved in the regulation of human leg lymphatic contractility.

In the present investigation, *in vitro* experiments were performed to determine

whether amines, acetylcholine, and some prostanoids elicited contraction in ring preparations from human groin lymphatics. In addition, an attempt was made to demonstrate adrenergic nerves in these lymphatics.

MATERIALS AND METHODS

Preparation and mounting

Lymphatics with an outer diameter of 0.2-0.4mm were taken from the groin from 20 patients (13 men and 7 women, aged 20 to 85 years, mean age 55 years) during vascular surgery. The tissue around a superficial lymph node was carefully dissected. After identification, lymphatics were extirpated together with the surrounding tissue and immediately placed in a chilled (4°C) Krebs solution of the following composition (in mM): NaCl 119, NaHCO₃ 15, KCl 4.6, CaCl₂ 1.5, NaH₂PO₄ 1.2, MgCl₂ 1.2 and glucose 11. All manipulations of the lymphatics were done using an operative microscope or with magnifying glasses. Special care was taken to avoid injury to the lymphatics. In one instance, a lymphatic ves-

sel was obtained from a patient (male, 44 years old) undergoing reconstructive surgery for lymphedema in the right leg. The lymphatic was removed from deep in the groin near the femoral vein.

The tissue sample was promptly transported to the laboratory. By means of an operative microscope (magnification x16), all fat was removed from around the lymphatic. It was divided into ring segments, which were suspended between two L-shaped metal holders (50 μ m in diameter) arranged in parallel (Fig. 1). The equipment is a modification of that described by Högestätt et al (12) for measurement of contractions in small blood vessels. In order not to destroy possible valves in the lymphatic, both metal holders were inserted from the same direction. One of the metal holders was attached to a Grass FTO3 C force-displacement transducer. The output from the transducer was amplified by and displayed on a Grass model 70 polygraph. The other holder was fixed to a movable unit. By a micrometer screw the movable unit could be displaced and a resting tension applied to the vessel. The vessel segments were submerged in temperature controlled (37°C) tissue baths,

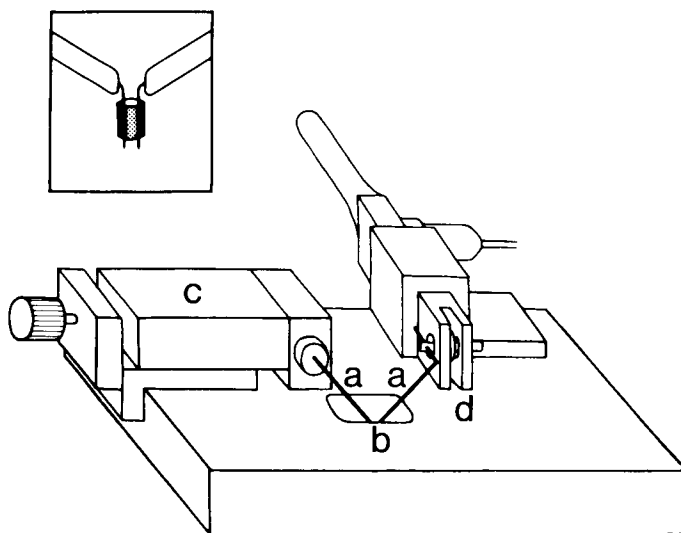

Fig. 1. Schematic drawing of the appliance used for measuring lymphatic contractility. L-shaped metal holders (a) with the vessel segment submerged in the organ bath (b). Movable unit (c) to strain the lymphatic to basal tension and the force-displacement transducer (d). Inset: one lymphatic segment suspended between the metal holders seen from above.

containing 2.5ml Krebs solution. The baths were bubbled with O₂ containing 5% CO₂ giving a pH of approximately 7.4. The vessels were repeatedly stretched until a stable basal tension of about 1.5mN was reached. They were allowed to equilibrate in the baths for 1 hour before the experiments started.

The operative microscope was equipped with a scaler, by which the distance between the metal holders and the length of the lymphatic segment was measured.

Experimental procedures

The segments were contracted by a pre-heated (37°C) and bubbled (95% O₂ + 5% CO₂) K⁺-rich Krebs solution of the following composition (in mM): KCl 124, NaHCO₃ 15, CaCl₂ 1.5, NaH₂PO₄ 1.2, MgCl₂ 1.2 and glucose 11. The preparation was submerged in the K⁺-rich solution until a stable tension was reached. Then the fluid in the tissue bath was frequently changed, resulting in a decrease of the amplitude below the starting tension. The lymphatics were again stretched to the basal tension and when the tension had stabilized a new K⁺-induced contraction was evoked. This was repeated until the predetermined tension level was reached after washing out the K⁺-rich solution (2-6 times). In separate experiments (n=6), basal tension was increased between repeated K⁺-induced contractions. It was revealed that optimum responses to K⁺ were obtained at basal tensions between 1 and 4 nM. All segments responding to K⁺ with contractions below 0.5mN were not used for further experiments. Agonists were added cumulatively. Only one agonist was used for each segment.

Histochemical examination

Immediately after extirpation some specimens of the lymphatics were frozen in a mixture of propane and propylene, quenched to the temperature of liquid nitrogen, freeze-dried and further processed according to the Falck and Hillarp procedure for the fluorescence-histochemical demonstration of adrenergic nerves (for details see (13)). Some specimens of the lymphatics were fixed for 4

hours in ice-cold freshly prepared 4% formaldehyde in phosphate buffered saline (PBS; pH 7.4) and then rinsed in ice-cold 15% sucrose in PBS during 48 hours (3 rinses). These specimens were then frozen in a mixture of propane and propylene at the temperature of liquid nitrogen. Cryostat section, cut at a thickness of 10µm, were processed according to the indirect immunofluorescence method of Coons (14) for the immunocytochemical demonstration of tyrosine hydroxylase (TH) and dopamine β-hydroxylase (DBH), known markers for adrenergic neuronal structures (15,16). The tissue structures were incubated at 4°C in a moist chamber for 3 days in the presence of rabbit antisera to TH and DBH (Eugene Tech., Allendale, USA), used in dilutions of 1:320 and 1:640 respectively. After rinsing in PBS the sections were exposed to fluorescein isothiocyanate (FITC)-conjugated swine anti-rabbit immunoglobulins diluted in PBS 1:20 (Dakopatts Ltd., Stockholm, Sweden) for one hour and at room temperature.

Drugs

Adrenalin barbitrate, noradrenalin hydrochloride (NA), dopamine hydrochloride, acetylcholine chloride, 5-hydroxytryptamine-creatinine sulphate (5-HT), PGE₂ (Sigma), PGF_{2α} (supplied as an aqueous solution, Amoglandin, Astra, Sweden) were tested. Dilutions were made in NaCl containing 1mM ascorbic acid. A stock solution of the prostaglandin endoperoxide (PGH₂) analogue U44069 ((15S)-hydroxy-9, 11-epoxymethano)prosta-5Z, 13 E-dienoic acid (Upjohn, USA) was made up in absolute ethanol (5mg/ml) and stored at -20°C. Fresh dilutions of U44069 were made with phosphate buffer at neutral pH just before use. The concentrations are given as final molar concentrations in the organ baths.

Analysis of data

Agonist-induced contractions were related to the maximal amplitude of the previous K⁺-induced contraction. All concentration-response curves were plotted

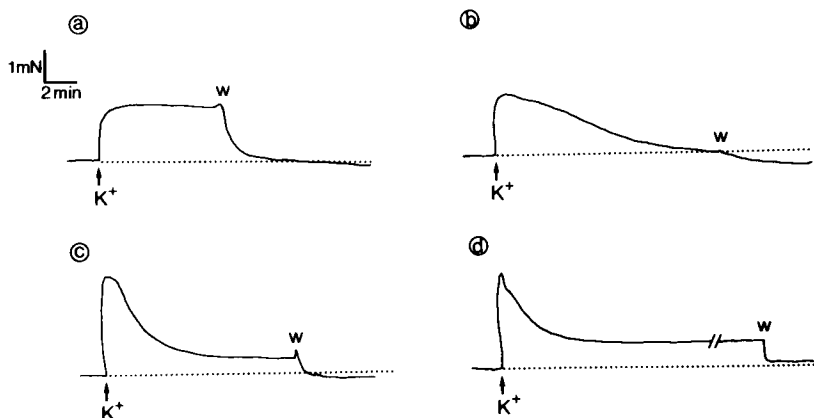

Fig. 2. Repeated K^+ -evoked contractions in one lymphatic segment. a), b), c), and d) show the first, second, fourth, and sixth contraction, respectively. The vessel was stretched between contractions until the basal tension was reached after washing (W) out the high K^+ -solution.

graphically and E_{max} , i.e., the maximum contraction obtained with an agonist, was established. The contraction was regarded as maximum when two subsequent contractions gave a response of the same amplitude or when the subsequent concentration produced a decreased contraction amplitude. The pEC_{50} -value, i.e., the negative logarithm of the EC_{50} -value, was determined from the graph as the concentration giving half maximal contraction. No pEC_{50} -value was determined when the maximum contraction was less than 10% of the K^+ -induced contraction. If not otherwise stated, the number of segments used in the experiments is equal to the number of patients.

RESULTS

Without experimental manipulation, the distance between the metal holders on the operative microscope at basal tension was 0.59 ± 0.05 mm, and the length of the lymphatic segment was 0.77 ± 0.04 mm (mean \pm S.E.M., $n=33$, superficial groin lymphatic segments from 15 patients).

Responses to K^+

About 35% of the segments (33 out of 90 segments from 20 patients) did not respond to

K^+ , and to some of these preparations NA and U44069 were added without any sign of contractility. The preparations responding to K^+ showed great variation in the ability to contract with maximal amplitudes ranging from 0.5 mN to 9.3 mN. In no segment was spontaneous contraction observed, not even after changes in applied tension within the range 0.1–8 mM. The K^+ -induced contractions changed in appearance on repeated exposure to the ion (Fig. 2). The initial contractions showed a rapid increase in tension which remained for several minutes at the maximal level and then slowly declined. Subsequently, the responses gradually developed an initial phasic contraction which was followed by a sustained increase in tension at a lower level. The maximum amplitude of the first, second and third contraction were 1.30 ± 0.21 mN, 1.88 ± 0.38 mN and 1.88 ± 0.30 mN, respectively (mean \pm SEM, $n=39$, segments from 16 patients). The responses to K^+ were not modified by blockade of NA uptake (cocaine $\times 10^{-6}$ M), β -adrenoreceptor blockade (propranolol 3×10^{-7} M), or α -adrenoreceptor blockade (phentolamine 10^{-6} M).

Responses to acetylcholine and amines

In experiments with lymphatics from four patients, acetylcholine and adrenaline

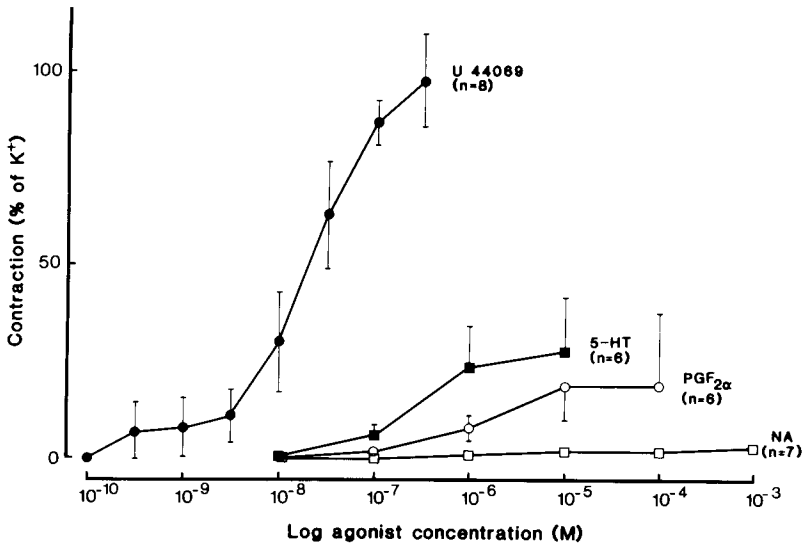

Fig. 3. Concentration response curves for U44069 (a PGH_2 -analog), serotonin (5-HT), prostaglandin $\text{F}_{2\alpha}$ ($\text{PGF}_{2\alpha}$) and noradrenalin (NA) in isolated human superficial groin lymphatics. The contractile responses are expressed as percentage of the K^+ (124mM)- induced contraction.

Table 1
Drug effect on contraction of isolated human superficial groin lymphatics.

	Number of Patients	E_{\max} (% of K^+) mean and range	pEC_{50} mean \pm SEM
Noradrenalin (NA)	7	2 (0-6)	—
Serotonin (5-HT)	6	25 (0-75)	6.7 ± 0.1
Prostaglandin $\text{F}_{2\alpha}$ ($\text{PGF}_{2\alpha}$)	6	20 (0-57)	6.1 ± 0.4
U44069	8	102 (73-155)	8.1 ± 0.1

(10^{-8} - 10^{-3} M) elicited no contractile response. High concentrations of dopamine (10^{-4} - 10^{-3} M) induced contraction in only one out of four vessel segments (E_{\max} was 6% of the K^+ -induced contraction). The results for NA are given in Table 1 and Fig. 3. The ability of NA to induce contraction was not enhanced by the addition of cocaine 10^{-6} M and/or propranolol 3×10^{-7} M or an increase of Ca^{2+} concentration in the bathing fluid to 2.5mM, or by exposing the lymphatic to a concentration of K^+ (10mM) not producing contraction. However, when NA in high concentrations (10^{-5} - 10^{-4} M) was superimposed on prostanoid-induced contractions, a con-

tractile response was observed (Fig. 4).

5-HT (10^{-8} - 10^{-4}) induced contractions with a maximum amplitude of 25% of the K^+ -induced response at a concentration of 10^{-5} M (Fig. 3, Table 1). Preparations from one out of six patients did not respond to 5-HT.

Responses to prostanoids

PGE_2 (5×10^{11} - 5×10^{-6} M) produced weak contractions at the highest concentration used in two out of four segments. The E_{\max} -values in these segments were 4% and 7% respectively. $\text{PGF}_{2\alpha}$ (10^{-8} - 10^{-4} M) also induced weak concentration-related re-

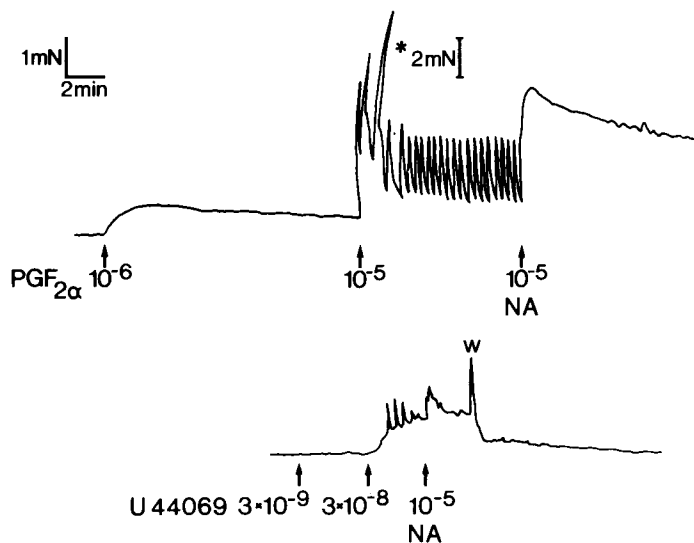

Fig. 4. Tracings from two experiments where noradrenalin (NA) 10^{-5} M was added on top of contractions evoked by prostaglandin $F_{2\alpha}$ (PGF $_{2\alpha}$) and U44069 at concentrations around their pEC_{50} -values. *Indicates a change in the sensitivity of the amplifier.

sponses at concentrations of 10^{-5} - 10^{-4} M (Fig. 3, Table 1). Preparations from two out of six patients did not respond to this prostanoïd. U44069 (3×10^{-10} - 10^{-6} M) elicited marked concentration-dependent contractions in all preparations (Fig. 3, Table 1). E_{max} was 102% and the pEC_{50} -value was 8.1. In half of the experiments phasic contractions were seen when PGF $_{2\alpha}$ or U44069 were present in the bath.

Responses to drugs in lymphedema

Five ring segments were cut from the lymphatic obtained from the patient with lymphedema. The size of these segments was similar to those of lymphatics from normal individuals. Two of the segments exhibited an irregular and transient spontaneous contractility before drug addition. U44069, PGF $_{2\alpha}$, 5-HT and NA each induced concentration dependent contractions (Fig. 5). U44069 and 5-HT were the most potent of these agents (Table 2). In contrast to U44069 and PGF $_{2\alpha}$, NA or 5-HT did not induce phasic contrac-

tions. To one segment, 10^{-5} M of the thromboxane receptor-blocking agent L636,499 (Merck, Frosst, Canada) was added 15 min prior to U44069, causing a slight rightward displacement of the U44069 concentration-response curve. The concentration-response curves are shown in Fig. 5, and the E_{max} and pEC_{50} -values are shown in Table 2.

Histochemical examination

Despite extensive sectioning of tissue specimens of the lymphatics ($n=4$), representative of the superficial lymphatics used in the functional studies, no adrenergic nerves displaying specific formaldehyde-induced catecholamine histofluorescence or immunoreactivities for TH and DBH were found.

DISCUSSION

In the human lower extremity there are two different lymphatic systems, one deep and one superficial. In this investigation we examined superficial lymphatics taken close to

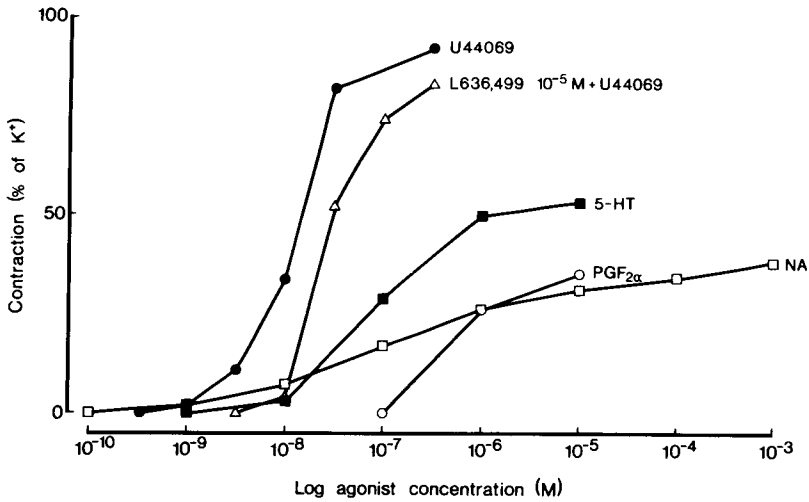

Fig. 5. Concentration-response curves for U44069 (a PGH_2 -analog), L636,499 (10^{-5} M) (a thromboxane blocker) + U44069, serotonin (5-HT), prostaglandin $\text{F}_{2\alpha}$ ($\text{PGF}_{2\alpha}$) and noradrenalin (NA) in isolated lymphatic segments from a patient with lymphedema. The contractile responses are expressed as percentage of the K^+ (124mM)-induced contraction.

Table 2
Drug effect on contraction of isolated
groin lymphatic from a patient with lymphedema

	E_{max} (% of K^+)	pEC_{50}
Noradrenalin (NA)	38	6.79
Serotonin (5-HT)	53	7.10
Prostaglandin $\text{F}_{2\alpha}$ ($\text{PGF}_{2\alpha}$)	35	6.33
U44069	92	7.88
L636,499 (10^{-5} M) + U44069	83	7.64

femoral lymph nodes. The wide variation in the contractile response to K^+ and the inability of some segments to contract may depend on irregular distribution of muscle cells along the lymphatic. Segments containing valves have a thinner wall than segments between valves where the lymphatic wall has more muscle cells (7). In some instances a lack of lymphatic contraction may relate to damage of these very small and fragile vessels during experimental handling.

Adrenergic nerves were not visualized in the superficial groin lymphatics despite adequate histochemical analysis. Adrenergic nerves in close contact to muscle cells have been demonstrated in the wall of the human

thoracic duct (17), and in mesenteric lymphatics from different animals (67). These discrepancies may reflect regional and species variations in the nervous supply to lymphatics. If lymphatics contain sympathetic nerves with axonic endings, NA, by activation of α -adrenergic receptors on the muscle cells should have exerted a contractile effect. However, in the present investigation, NA elicited no or only a weak contraction even in the presence of the β -adrenergic blocker propranolol and the neuronal uptake blocker cocaine. Furthermore, the effects of K^+ were not influenced by propranolol, cocaine or phentolamine, supporting the view that in human groin lymphatics K^+ does not release

NA in contrast to bovine mesenteric lymphatics (18). These findings conform to the histological findings and support the absence of adrenergic innervation in superficial human groin lymphatics. It should be stressed, however, that this finding may not apply to lymphatics from other regions. The lack of lymphatic contractile effect by NA is at variance with other results obtained in animal lymphatics. Thus NA-induced contractions in ring preparations of bovine (19-21) and sheep (21) mesenteric lymphatics. Ohhashi and Azuma (22) showed that phenylephrine (α_1 -agonist) and clonidine (α_2 -agonist) both caused contraction in ring preparations from bovine mesenteric lymphatics. Prazosin (α_1 -agonist) and yohimbine (α_2 -agonist) competitively inhibited these responses suggesting both α_1 - and α_2 -like adrenergic receptors on lymphatic smooth muscle cells. In the present study, acetylcholine, adrenalin, and dopamine had little or no contractile effects. 5-HT produced contractions as found in sheep and bovine mesenteric lymphatics (21), but its functional significance is unclear.

In isolated sheep and bovine lymphatics $\text{PGF}_{2\alpha}$, PGE_2 , PGD_2 , and PGI_2 had no contractile effects (21). In human lymphatics Sinzinger et al (11) found PGE_1 , but not PGI_2 to have a small contractile action. In the present study PGE_2 and $\text{PGF}_{2\alpha}$ produced weak contractions, whereas U44069 (a PGH_2 -analog) consistently had a marked concentration-dependent contractile effect. These findings support the suggestion of Sinzinger (11) that PGH_2 and thromboxane A_2 (TXA_2) have a role in regulating human lymphatic contractility. However, further investigations including lymphatics from different regions are necessary to get sufficient information about the functional significance of TXA_2 -receptors in human lymphatics.

The lymphatics from the patient with lymphedema seemed more sensitive to NA and 5-HT than "normal" lymphatics. It is unwise to draw a firm conclusion from a single experiment, but it may be speculated that there is altered sensitivity to contractile agents in lymphedema.

In conclusion, our results suggest a lack of sympathetic innervation and contraction-mediating α -adrenergic receptors in superfi-

cial human groin lymphatics. The marked effect of U44069, a PGH_2 analog suggests that some prostanoids are important for regulation of human lymphatic contractility.

REFERENCES

1. Carlsten, A, J Kjellner: Normal physiology and pathophysiology. In: *Venous and Lymphatic Disorders of the Leg* (Haeger, K, Ed.). Scandinavian University Books, Lund, Sweden (1966), 21-42.
2. Yoffey, JM, FC Courtice: *Lymphatics, Lymph, and the Lymphomyeloid Complex*. Academic Press, London & New York (1970).
3. McHale, NG: Innervation of the lymphatic circulation. In: *Experimental Biology of the Lymphatic Circulation* (Johnston, MG, Ed.). Elsevier Science Publishers, B.V. (1985), 121-140.
4. Johnston, MG: Involvement of lymphatic collecting ducts in the physiology and pathophysiology of lymph flow. In: *Experimental Biology of the Lymphatic Circulation* (Johnston, MG, Ed.). Elsevier Science Publishers, B.V. (1985), 81-120.
5. Ohhashi, T, Y Kawai, T Azuma: The response of lymphatic smooth muscles to vasoactive substances. *Pflugers Arch.* 375 (1978), 183.
6. Ohhashi, T, S Kobayashi, S Tsukahara, et al: Innervation of bovine mesenteric lymphatics: From the histochemical point of view. *Microvasc. Res.* 24 (1982), 377.
7. Alessandrini, C, R Gerli, G Sacchi, et al: Cholinergic and adrenergic innervation of mesenteric lymph vessels in guinea pig. *Lymphology* 14 (1981), 1.
8. McHale, NG, IC Roddie, KD Thornbury: Nervous modulation of spontaneous contractions in bovine mesenteric lymphatics. *J. Physiol.* 309 (1980), 461.
9. McHale, NG, IC Roddie: The effect of transmural pressure on pumping activity in isolated bovine lymphatic vessels. *J. Physiol.* 261 (1976), 255.
10. Olszewski, WL, A Engeset: Intrinsic contractility of prenodal lymph vessels and lymph flow in human leg. *Am. J. Physiol.* 239 (1980), H774.
11. Sinzinger, H, J Kaliman, E Mannheimer: Regulation of human contractility by prostaglandins and thromboxane. *Lymphology* 17 (1984), 43.
12. Högestätt, ED, K-E Andersson, L Edvinsson: Mechanical properties of rat cerebral arteries as studied by a sensitive device for recording of

- mechanical activity in isolated small blood vessels. *Acta Physiol. Scand.* 117 (1983), 49.
13. Björklund, A, B Falck, C Owman: Fluorescence microscopic and microspectrofluorometric techniques for the cellular localization and characterization of biogenic amines. In: *Methods of Investigative and Diagnostic Endocrinology* (Rall, JE, IJ Kopin, Eds.). North-Holland Publication Company, Amsterdam (1972), 318-368.
 14. Coons, AH, EH Leduc, JM Conolly: Studies on antibody production. I. A method for the histochemical demonstration of specific antibody and its application to a study of the hyperimmune rabbit. *J. Exp. Med.* 102 (1955), 49.
 15. Pickel, VM, TH Jok, PM Field, et al: Cellular localization of tyrosine hydroxylase by immunohistochemistry. *J. Histochem. Cytochem.* 23 (1975), 1.
 16. Rush, RH, LB Geffen: Dopamine β -hydroxylase in health and disease. *CRC Crit. Rev. Clin. Lab. Sci.* 12 (1980), 241.
 17. Wenzel, J: Normale Anatomie des Lymphgefäßsystems. In: *Handbuch Allg. Pathol. Bd. III/6*. Springer, Berlin, Heidelberg, New York, (1972), 89-148.
 18. Ohhashi, T, T Azuma, ID Roddie: Effect of potassium on adrenergic nerve endings in bovine mesenteric lymphatics. *J. Auton. Nervous System* 8 (1983), 205.
 19. Allen, JM, NG McHale, BM Rooney: Effect of norepinephrine on contractility of isolated lymphatics. *Am. J. Physiol.* 244 (1983), H479.
 20. McHale, NG, IC Roddie: The effects of catecholamines on pumping activity in isolated bovine mesenteric lymphatics. *J. Physiol.* 338 (1983), 527.
 21. Johnston, MG, JL Gordon: Regulation of lymphatic contractility by arachidonate metabolites. *Nature* 293 (1981), 294.
 22. Ohhashi, T, T Azuma: Pre- and post-junctional α -adrenoceptors at sympathetic neuroeffector junction in bovine mesenteric lymphatics. *Microvasc. Res.* 31 (1986), 31.

Trygve Sjöberg
Department of Surgery
Lund University
S-221 85 Lund
Sweden